

PARTS LIST

Left front splash guard

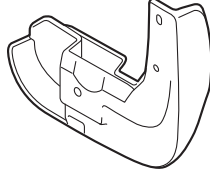

Right front splash guard

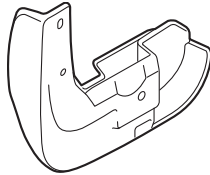

Left rear splash guard

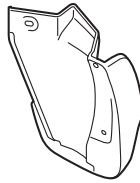

Right rear splash guard



8 Self-tapping screws, 5 x 25 mm



2 Spring nuts

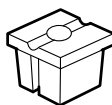

2 Grommets A

 2 Grommets B
(May not be used)

2 Self-tapping screws, 5 x 30 mm

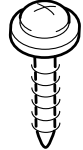

2 Self-tapping screws, 5 x 20 mm

TOOLS AND SUPPLIES REQUIRED

Phillips screwdriver

Stubby Phillips screwdriver

Small flat-tip screwdriver

Trim Tool Set (T/N SOJATP2014)

Pushpin

High-quality paste wax

INSTALLATION

Customer Information: The information in this installation instruction is intended for use only by skilled technicians who have the proper tools, equipment, and training to correctly and safely add equipment to your vehicle. These procedures should not be attempted by "do-it-yourselfers."

NOTE:

- Be careful not to damage the paint finish.
- These instructions show the left splash guards being installed. The same procedure applies to installing the right splash guards.
- Clean and wax the areas to be covered with a high-quality paste wax.

Installing the Front Splash Guards

1. Turn the steering wheel fully counterclockwise.
2. Using a pushpin, pierce the centers of three clips in the left front inner fender.

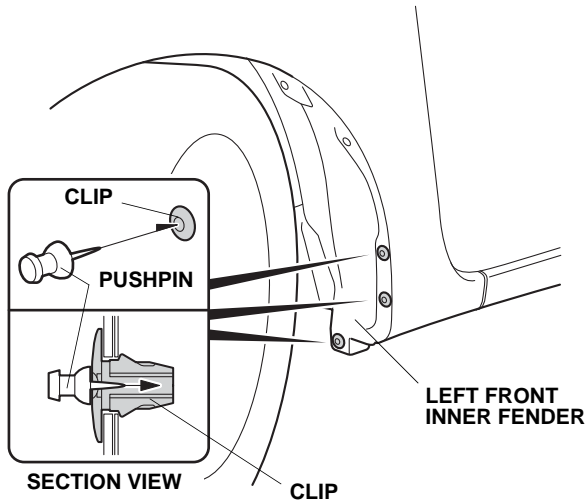

3. Secure the left front splash guard with three 5 x 25 mm self-tapping screws in the order shown below.

NOTE: If there is a gap between the splash guard and the body, loosen the three self-tapping screws, adjust the splash guard, and retighten the self-tapping screws.

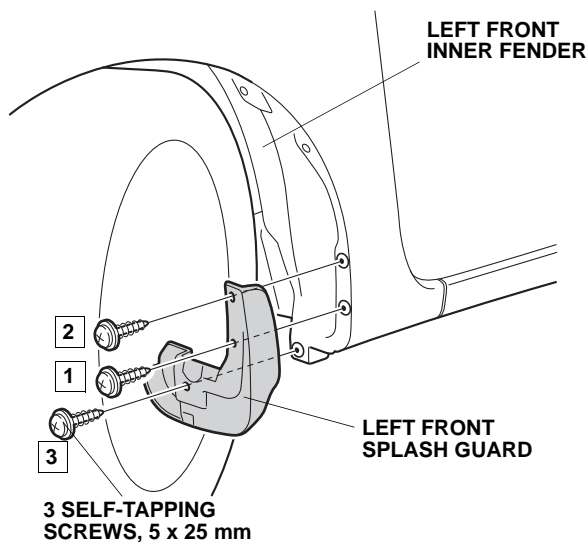

4. Turn the steering wheel fully clockwise, and repeat steps 2 and 3 to install the right front splash guard.

Installing the Rear Splash Guards

If the vehicle is equipped with fender covers, do steps 5 through 12. If not, go to step 13.

5. Working inside the fenderwell, use a small flat-tip screwdriver to release the tabs on the clip, then remove the clip with a trim tool set.

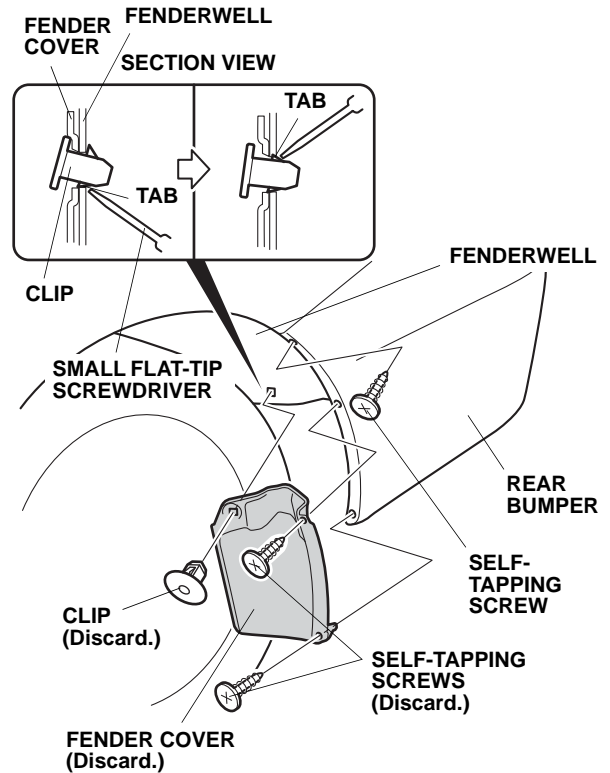

6. Remove three self-tapping screws from the rear bumper, and remove the fender cover.
7. Pull the rear bumper away from the body, and release the seven retaining tabs.

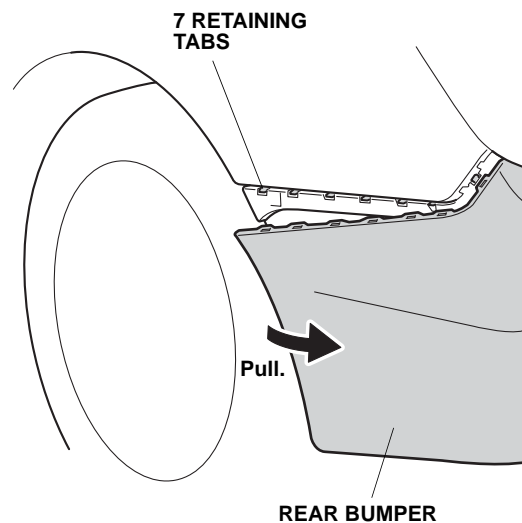

- Install a grommet B into the hole in the fenderwell.

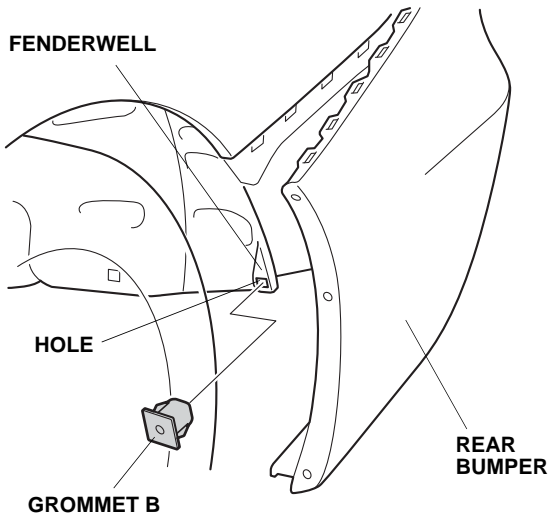

- Reinstall the rear bumper onto the retaining tabs, and reinstall one self-tapping screw. Install a grommet A into the hole in the fenderwell.

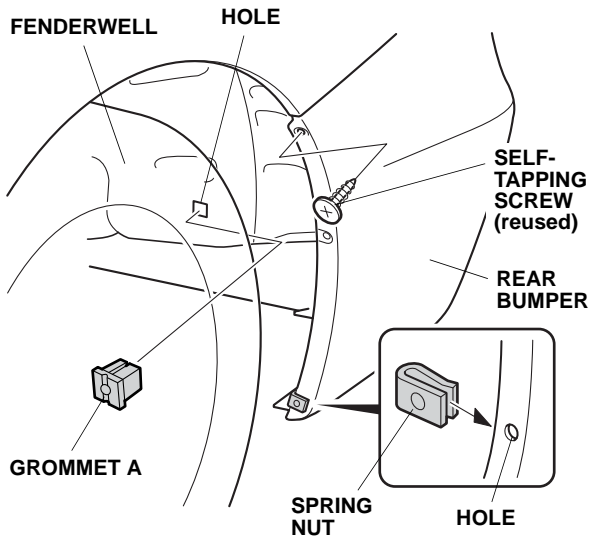

- Install a spring nut over the hole in the rear bumper.

- Secure the left rear splash guard with one 5 x 20 mm self-tapping screw, one 5 x 25 mm self-tapping screw, and one 5 x 30 mm self-tapping screw in the order shown below.

NOTE: If there is a gap between the splash guard and the body, loosen the three self-tapping screws, adjust the splash guard, and retighten the self-tapping screws.

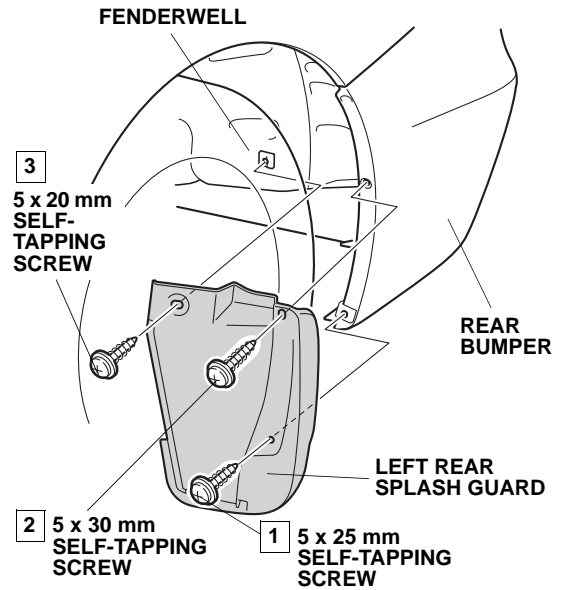

- Repeat steps 5 through 11 to install the right rear splash guard.
- Remove one self-tapping screw from the rear bumper.

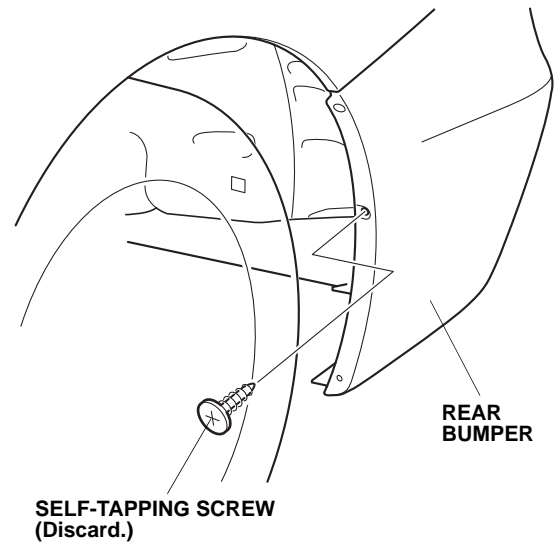

- Using a pushpin, pierce the dimple in the rear bumper.

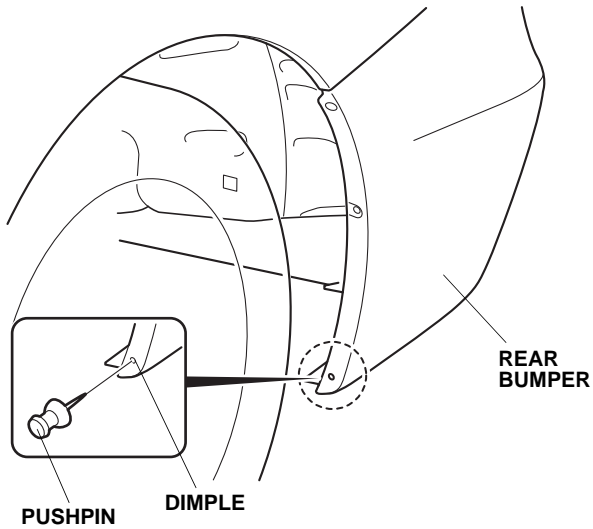

- Install a grommet A into the hole in the fenderwell.

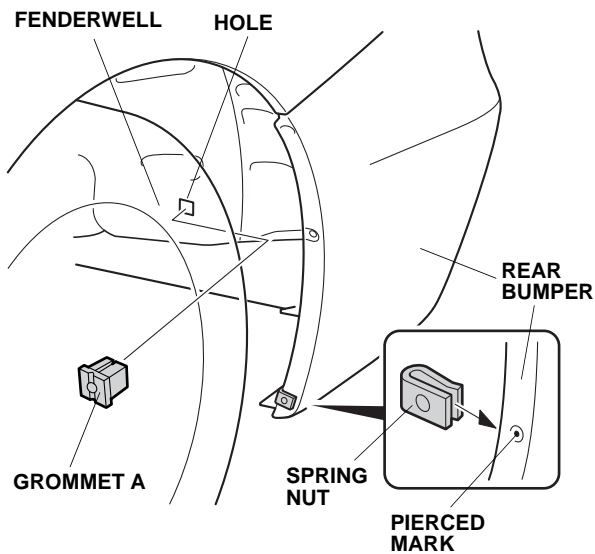

- Install a spring nut over the pierced mark in the rear bumper.

- Secure the left rear splash guard with one 5 x 20 mm self-tapping screw, one 5 x 25 mm self-tapping screw, and one 5 x 30 mm self-tapping screw in the order shown below.

NOTE: If there is a gap between the splash guard and the body, loosen the three self-tapping screws, adjust the splash guard, and retighten the self-tapping screws.

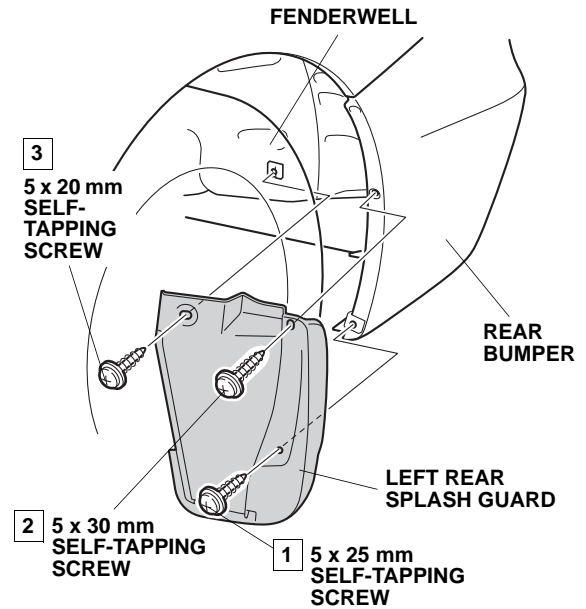

- Repeat steps 13 through 17 to install the right rear splash guard.